

# HIT photovoltaic module

# HIP-210NKHE5

The SANYO HIT (Heterojunction with Intrinsic Thin layer) solar cell is made of a thin mono crystalline silicon wafer surrounded by ultra-thin amorphous silicon layers. This product provides the industry's leading performance and value using state-of-the-art manufacturing techniques.



## Benefit in Terms of Performance

The HIT cell and module have very high conversion efficiency in mass production.

Model	Cell Efficiency	Module Efficiency
HIP-210NKHE5	18.9%	16.7%

## High performance at high temperatures

Even at high temperatures, the HIT solar cell can maintain higher efficiency than a conventional crystalline silicon solar cell.

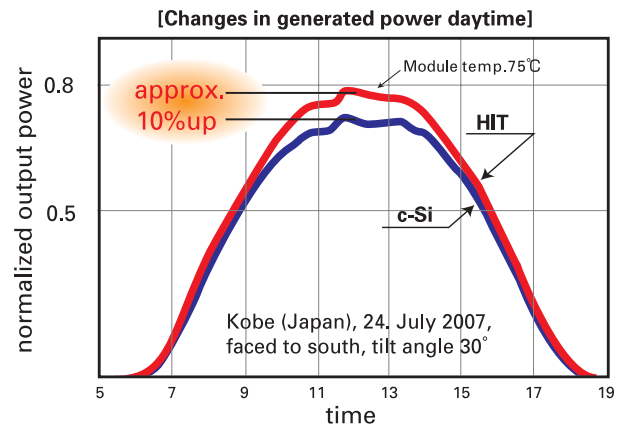

## HIT Solar Cell Structure

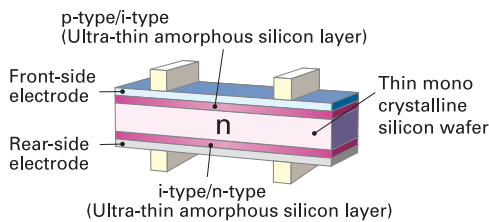

Development of HIT solar cell was supported in part by the New Energy and Industrial Technology Development Organization (NEDO).

## Environmentally-Friendly Solar Cell More Clean Energy

HIT can generate more clean Energy than other conventional crystalline solar cells.

## Special Features

SANYO HIT solar modules are 100% emission free, have no moving parts and produce no noise. The dimensions of the HIT modules allow space-saving installation and achievement of maximum output power possible on given roof area.

Models HIP-210NKHE5		
<b>Electrical data</b>		
Maximum power (Pmax)	[W]	210
Max. power voltage (Vmp)	[V]	41.3
Max. power current (Imp)	[A]	5.09
Open circuit voltage (Voc)	[V]	50.9
Short circuit current (Isc)	[A]	5.57
Warranted minimum power (Pmin)	[W]	199.5
Maximum over current rating	[A]	15
Output power tolerance	[%]	+10/-5
Maximum system voltage	[V]	1000
Temperature coefficient of Pmax	[%/°C]	-0.30
	Voc [V/°C]	-0.127
	Isc [mA/°C]	1.67

Note 1: Standard Test Conditions: Air mass 1.5, Irradiance = 1000W/m<sup>2</sup>, Cell temperature = 25°C  
 Note 2: The values in the above table are nominal

Reference data for model HIP-210NKHE5

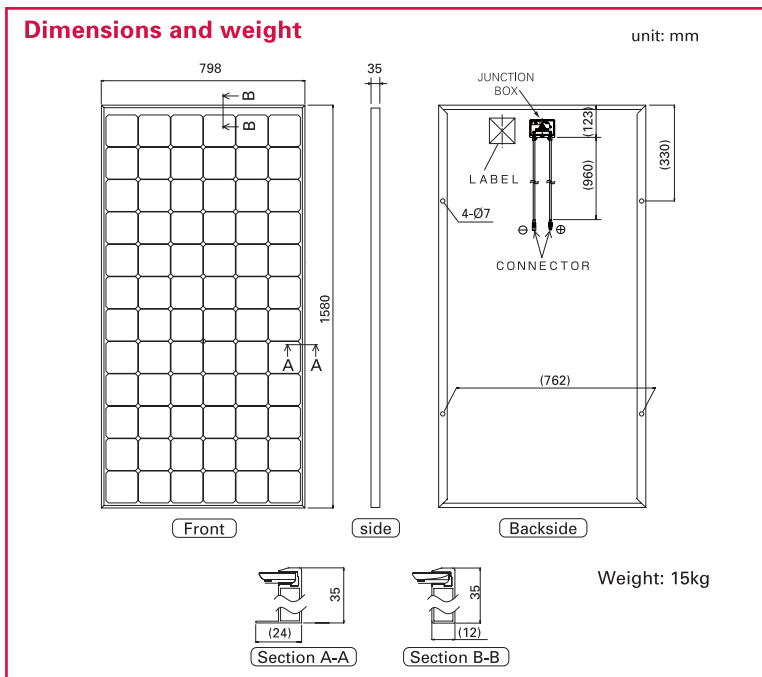
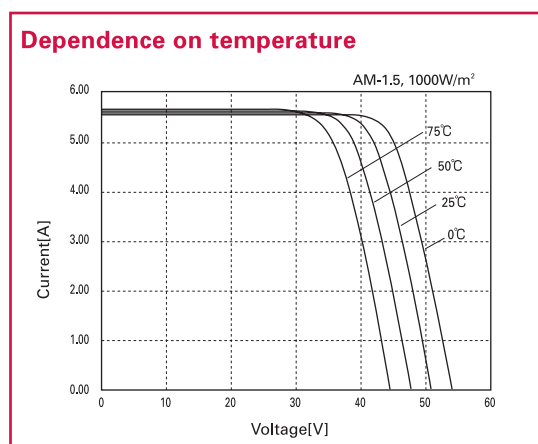
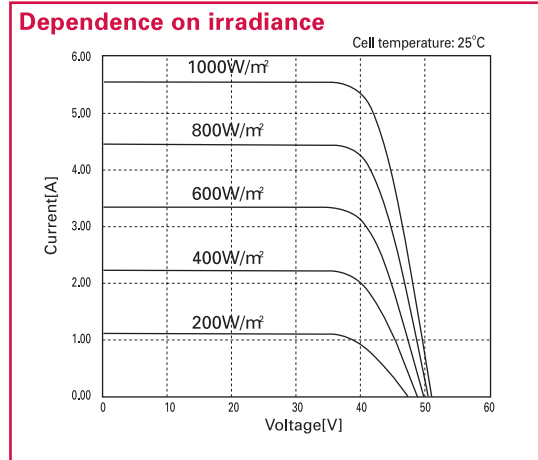

**Certificates**

IEC 61730 IEC 61215

• Safety tested, IEC 61730  
 • Periodic Inspection

Electrical Protection Class II

Please consult your local dealer for more information.

**CAUTION!** Please read the operating instructions carefully before using the products.  
 Due to our policy of continual improvement the products covered by this brochure may be changed without notice.

**SANYO Oceania Pty. Ltd.**  
 PO Box 947 North Ryde BC NSW 1670  
 Tower A Ground Floor 112-118 Talavera Road  
 North Ryde Australia NSW 2113  
 Tel. 61-2-9815-5822 Fax. 61-2-9815-5981  
 URL: <http://www.sanyo.com.au/>



**SANYO Electric Co., Ltd.**  
 Solar Division

<http://www.sanyo.com/solar>  
 E-mail: [homepage\\_solar@sanyo.com](mailto:homepage_solar@sanyo.com)